

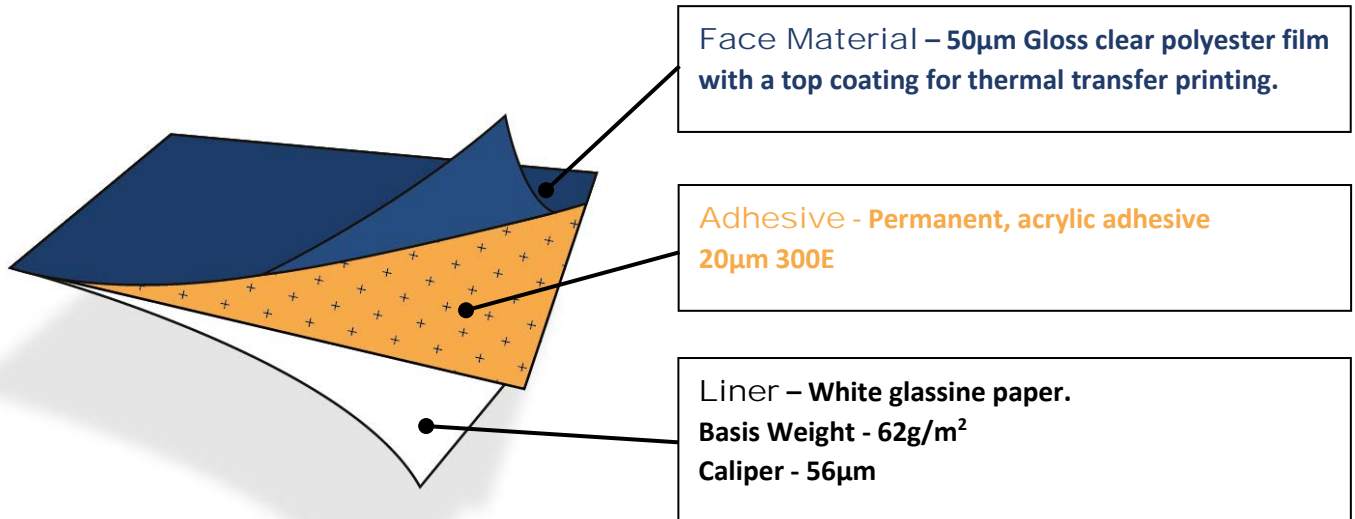

Data Sheet - #184

3M7861E GLOSS CLEAR POLYESTER PERMANENT



General #184 is a gloss clear polyester film with a top coating for thermal transfer printing. Resin ribbons are recommended for optimum durability. The facestock provides durability in harsh environments.

Applications The adhesive bonds well to a wide variety of substrates including metals, high surface energy (HSE) plastics and low surface energy (LSE) plastics. It is ideal for applications requiring high initial adhesion especially to LSE plastic surfaces. Some applications include barcode labels & rating plates, property identification, asset labelling in harsh environments, warning, instruction and service labels for durable goods and nameplate labels.

Application temperature 5°C

Service temperature -40°C to +150°C

Product life 2 years when stored at 21°C | 50% RH

Special considerations For maximum bond strength, the surface should be clean and dry. Isopropyl alcohol is a typical cleaning agent. For best bonding conditions, application surface should be at room temperature or higher. Low temperature surfaces, below 5°C can cause the adhesive to become so firm that it will not develop maximum contact with the substrate. Higher initial bonds can be achieved through increased rubdown pressure. UL and cUL approved (File Number MH18072).

All data given is considered reliable but does not constitute a warranty. It is the responsibility of the user to satisfy themselves as to the suitability of the product for the particular application and conditions. A sample for this purpose will be supplied on request.